



COMPONENTS MAINTENANCE MANUAL  
LED FLASHLIGHT AND LED FLASHLIGHT BRACKET

**COMPONENT MAINTENANCE MANUAL  
WITH  
ILLUSTRATED PARTS LIST**

**LED FLASHLIGHT**

**P3APP005000A**

**LED FLASHLIGHT BRACKET**

**P3APP005001A**

THIS DOCUMENT CONTAINS TECHNOLOGY OR TECHNICAL DATA NOT CONTROLLED UNDER GERMAN REGULATIONS. IT MAY CONTAIN 9A610.Y OR EAR99 TECHNICAL DATA. HOWEVER LOCAL REGULATIONS APPLY.



COMPONENTS MAINTENANCE MANUAL  
LED FLASHLIGHT AND LED FLASHLIGHT BRACKET

**Copyright © 2023 Umlaut engineering GmbH.**

**PROPRIETARY INFORMATION DISCLOSURE RESTRICTION**

The information contained in this document is umlaut engineering GmbH proprietary information. It is disclosed in confidence and is intended for internal use only by umlaut engineering GmbH authorized owner/lessee operators and repair stations. It is the property of umlaut engineering GmbH and must not be altered, reused, disclosed to others or reproduced for distribution or redistribution in any form, paper or electronic, without the express written consent of umlaut engineering GmbH. This includes but is not limited to its use in the creation, manufacture, development, or derivation of any repairs, modifications, spare parts, design, or configuration changes or to obtain FAA or any other government or regulatory approval to do so. If consent is given for reproduction in whole or part, this notice must appear in any such reproduction in whole.

Umlaut engineering GmbH assumes no liability whatsoever, whether contractual, warranty, tort or otherwise, for unauthorized alteration or alterations not performed in accordance with umlaut engineering GmbH approved procedures.



COMPONENTS MAINTENANCE MANUAL  
LED FLASHLIGHT AND LED FLASHLIGHT BRACKET

**HIGHLIGHTS**

TO: HOLDERS OF COMPONENT MAINTENANCE MANUAL FOR FLASHLIGHT, ATA 25-60-04  
REVISION NO. 00

PAGE BLOCK	DESCRIPTION OF CHANGE
All	New revision



COMPONENTS MAINTENANCE MANUAL  
LED FLASHLIGHT AND LED FLASHLIGHT BRACKET

INTENTIONALLY LEFT BLANK



COMPONENTS MAINTENANCE MANUAL  
LED FLASHLIGHT AND LED FLASHLIGHT BRACKET

**RECORD OF REVISIONS**

RE. NO.	ISSUE DATE	INSERTED DATE	
		DATE	BY
00	13.11.2023		

RE. NO.	ISSUE DATE	INSERTED DATE	
		DATE	BY

Retain this record in the front of the manual.

On the receipt of revisions, insert revised page in the manual and enter revision number, date and initials.



COMPONENTS MAINTENANCE MANUAL  
LED FLASHLIGHT AND LED FLASHLIGHT BRACKET

INTENTIONALLY LEFT BLANK



COMPONENTS MAINTENANCE MANUAL  
LED FLASHLIGHT AND LED FLASHLIGHT BRACKET  
**LIST OF SERVICE BULLETINS**

NOT APPLICABLE

**25-60-04**

Rev. No.  
Rev. Date  
Page

00  
Nov 13/2023  
SBL 1



COMPONENTS MAINTENANCE MANUAL  
LED FLASHLIGHT AND LED FLASHLIGHT BRACKET

INTENTIONALLY LEFT BLANK





COMPONENTS MAINTENANCE MANUAL  
LED FLASHLIGHT AND LED FLASHLIGHT BRACKET

<u>SUBJECT</u>	<u>PAGE</u>	<u>DATE</u>	<u>RE</u>	<u>SUBJECT</u>	<u>PAGE</u>	<u>DATE</u>	<u>RE</u>
<u>TITLE PAGE</u>				<u>INTRODUCTION</u>			
	TITLE 1	Nov 13/2023	00		INTRO 1	Nov 13/2023	00
	TITLE 2	Nov 13/2023	00		INTRO 2	Nov 13/2023	00
					INTRO 3	Nov 13/2023	00
<u>HIGHLIGHTS</u>					INTRO 4	Nov 13/2023	00
	HIGHLIGHTS 1	Nov 13/2023	00	<u>DESCRIPTION AND OPERATION</u>			
	HIGHLIGHTS 2	Nov 13/2023	00				
<u>RECORD OF REVISIONS</u>					1	Nov 13/2023	00
					2	Nov 13/2023	00
					3	Nov 13/2023	00
	ROR 1	Nov 13/2023	00		4	Nov 13/2023	00
	ROR 2	blank	00	<u>TESTING AND FAULT ISOLATION</u>			
<u>SERVICE BULLETIN LIST</u>					1001	Nov 13/2023	00
					1002	Nov 13/2023	00
	SBL 1	Nov 13/2023	00		1003	Nov 13/2023	00
	SBL 2	blank	00		1004	blank	00
<u>LIST OF EFFECTIVE PAGES</u>				<u>DISASSEMBLY</u>			
	LEP 1	Nov 13/2023	00		3001	Nov 13/2023	00
	LEP 2	Nov 13/2023	00		3002	blank	00
<u>TABLE OF CONTENTS</u>				<u>CLEANING</u>			
	TOC 1	Nov 13/2023	00		4001	Nov 13/2023	00
	TOC 2	Nov 13/2023	00		4002	blank	00
<u>LIST OF ILLUSTRATIONS</u>				<u>INSPECTION/CHECK</u>			
	LOI 1	Nov 13/2023	00		5001	Nov 13/2023	00
	LOI 2	blank	00		5002	Nov 13/2023	00
					5003	Nov 13/2023	00
					5004	Nov 13/2023	00
<u>LIST OF TABLES</u>					5005	Nov 13/2023	00
	LOT 1	Nov 13/2023	00				
	LOT 2	blank	00				



COMPONENTS MAINTENANCE MANUAL  
LED FLASHLIGHT AND LED FLASHLIGHT BRACKET

<u>SUBJECT</u>	<u>PAGE</u>	<u>DATE</u>	<u>RE</u>	<u>SUBJECT</u>	<u>PAGE</u>	<u>DATE</u>	<u>RE</u>
<u>REPAIR</u>				<u>STORAGE INCLUDING TRANSPORTATION</u>			
	6001	Nov 13/2023	00		15001	Nov 13/2023	00
	6002	Nov 13/2023	00		15002	blank	00
	6003	blank	00				
<u>ASSEMBLY</u>				<u>REWORK</u>			
	7001	Nov 13/2023	00		16001	Nov 13/2023	00
	7002	Nov 13/2023	00		16002	blank	00
<u>FITS AND CLEARANCES</u>				<u>ILLUSTRATED PARTS LIST</u>			
	8001	Nov 13/2023	00		IPL-TP 10001	Nov 13/2023	00
	8002	blank	00		IPL-TP 10002	blank	00
<u>SPECIAL TOOLS, FIXTURES, EQUIPMENT AND CONSUMABLES</u>				<u>IPL - INTRODUCTION</u>			
					INTRO 10001	Nov 13/2023	00
	9001	Nov 13/2023	00		INTRO 10002	Nov 13/2023	00
	9002	blank	00		INTRO 10003	Nov 13/2023	00
					INTRO 10004	blank	00
<u>SPECIAL PROCEDURES</u>				<u>NUMERICAL INDEX</u>			
	11001	Nov 13/2023	00				
	11002	blank	00		NI 10001	Nov 13/2023	00
					NI 10002	blank	00
<u>REMOVAL</u>				<u>DETAILED PARTS LIST</u>			
	12001	Nov 13/2023	00		DPL10001	Nov 13/2023	00
	12002	blank	00		10001-1	Nov 13/2023	00
<u>INSTALLATION</u>					10001-2	Nov 13/2023	00
					10002-1	Nov 13/2023	00
	130001	Nov 13/2023	00		10002-2	Nov 13/2023	00
	130002	blank	00				
<u>SERVICING</u>							
	14001	Nov 13/2023	00				
	14002	blank	00				



COMPONENTS MAINTENANCE MANUAL  
LED FLASHLIGHT AND LED FLASHLIGHT BRACKET

**TABLE OF CONTENTS**

INTRODUCTION..... INTRO 1

1. GENERAL.....INTRO 1

2. MANUFACTURING .....INTRO 1

3. LAYOUT OF THE MANUAL .....INTRO 1

4. REVISION SERVICE.....INTRO 1

5. VALIDATION OF OPERATIONS DESCRIBED IN THIS MANUAL.....INTRO 2

6. WARNINGS, CAUTIONS, NOTES.....INTRO 2

7. IDENTIFYING REVISED MATERIAL.....INTRO 2

8. LIST OF ABBREVIATIONS .....INTRO 2

DESCRIPTION AND OPERATION ..... 1

1. GENERAL .....1

2. DESCRIPTION .....2 & 3

3. OPERATION.....4

TESTING AND FAULT ISOLATION .....1001

1. GENERAL .....1001

2. TESTING.....1001

3. FAULT ISOLATION.....1002

DISASSEMBLY ..... 3001

1. GENERAL .....3001

2. DISASSEMBLY PROCEDURES .....3001

CLEANING ..... 4001

1. GENERAL .....4001

INSPECTION/CHECK ..... 5001

1. GENERAL .....5001

2. CHECK.....5001

3. CHECK.....5004

REPAIR..... 6001

1. GENERAL .....6001

2. REPAIR PROCEDURES.....6001

3. REPAIR PROCEDURES.....6002

ASSEMBLY..... 7001

1. GENERAL .....7001

2. ASSEMBLY OF THE FLASHLIGHT (BATTERY INSTALLATION) .....7001



COMPONENTS MAINTENANCE MANUAL  
LED FLASHLIGHT AND LED FLASHLIGHT BRACKET

TABLE OF CONTENTS

FITS AND CLEARANCES ..... 8001

SPECIAL TOOLS, FIXTURES, EQUIPMENT AND CONSUMABLES ..... 9001

SPECIAL PROCEDURES.....11001

REMOVAL..... 12001

    1. GENERAL ..... 12001

    2. REMOVAL OF THE FLASHLIGHT AND THE BRACKET. .... 12001

INSTALLATION ..... 13001

    1. GENERAL ..... 12001

    2. INSTALLATION OF THE FLASHLIGHT AND THE BRACKET..... 12001

SERVICING ..... 14001

STORAGE INCLUDING TRANSPORTATION..... 15001

    1. STORAGE APPLICABLE. ....15001

REWORK ..... 16001

ILLUSTRATED PARTS LIST..... PL-TP 10001

IPL INTRODUCTION..... NTRO 10001

NUMERICAL INDEX ..... NI 10001

DETAILED PARTS LIST..... DPL 10001

FIGURE 1: LED FLASHLIGHT ..... 10001-1

FIGURE 2: LED FLASHLIGHT BRACKET .....10002-1



COMPONENTS MAINTENANCE MANUAL  
LED FLASHLIGHT AND LED FLASHLIGHT BRACKET  
LIST OF ILLUSTRATIONS

<u>TITLE</u>	<u>FIGURE</u>	<u>PAGE</u>
UPDATE OF THE FLASHLIGHT EXPIRATION DATE	FIGURE 5001	5003
ASSEMBLY OF THE FLASHLIGHT ( BATTERY INSTALLATION)	FIGURE 7001	7002
LED FLASHLIGHT	FIGURE 1	10001-1
LED FLASHLIGHT BRACKET	FIGURE 2	10002-1



COMPONENTS MAINTENANCE MANUAL  
LED FLASHLIGHT AND LED FLASHLIGHT BRACKET

INTENTIONALLY LEFT BLANK



COMPONENTS MAINTENANCE MANUAL  
LED FLASHLIGHT AND LED FLASHLIGHT BRACKET

LIST OF TABLES

<u>TITLE</u>	<u>TABLE</u>	<u>PAGE</u>
LIST OF ABBREVIATIONS	TABLE 1	INTRO 3
TECHNICAL DATA	TABLE 2	2
TECHNICAL DATA	TABLE 3	3
FLASHLIGHT SYSTEM FAULT ISOLATION	TABLE 1001	1003
CLEANING CONSUMABLES	TABLE 4001	4001
CHECK OF THE LED FLASHLIGHT SYSTEM	TABLE 5001	5001
CHECK OF THE LED FLASHLIGHT BRACKET	TABLE 5002	5004
FLASHLIGHT ASSEMBLY CONSUMABLES	TABLE 7001	7001



COMPONENTS MAINTENANCE MANUAL  
LED FLASHLIGHT AND LED FLASHLIGHT BRACKET

INTENTIONALLY LEFT BLANK





COMPONENTS MAINTENANCE MANUAL  
LED FLASHLIGHT AND LED FLASHLIGHT BRACKET

**INTRODUCTION**

**\*\* FOR PNs P3APP005000A P3APP005001A**

TASK 25-60-04-871-801-A01

Introduction

**CAUTION:** THIS MANUAL PROVIDES THE NECESSARY INFORMATION TO PERFORM THE REPAIR IN AN INTERMEDIATE LEVEL MAINTENANCE SHOP (I - LEVEL).

THE THIRD LEVEL OF MAINTENANCE (D - LEVEL) IS NOT APPLICABLE IN THIS MANUAL.

1. General

- A. This manual 25-60-04 (Internal number : P3DOC004218) has been compiled entirely from a SGML source in accordance with the requirements set out in the specification ATA iSpec 2200. It provides data as necessary for an approved repairer to restore an unserviceable FLASHLIGHT to a serviceable condition.

2. Manufacturing

- A. The LED FLASHLIGHT and the LED FLASHLIGHT BRACKET are manufactured and product supported by:

umlaut engineering GmbH\*

Blohmstraße 12

21079 Hamburg

Germany

Internet: [www.umlaut.com](http://www.umlaut.com)

\*umlaut engineering GmbH (part of Accenture)

3. Layout of the Manual

- A. This manual contains a general description and operation followed by data for testing, check and repair instructions of the LED FLASHLIGHT and the LED FLASHLIGHT BRACKET. An ILLUSTRATED PARTS LIST is also included.

4. Revision Service

- A. This manual 25-60-04 (Internal number: P3DOC004218) will be updated as required by revisions. Service Bulletins (SBs) may be issued separately. Their effect on the manual will, however, be evident by reissue of the SB as appropriate.



COMPONENTS MAINTENANCE MANUAL  
LED FLASHLIGHT AND LED FLASHLIGHT BRACKET

5. Validation of Operations described in this Manual

- A. The maintenance operations described in this manual have been checked in manufacturer's workshops by an exact carrying out of dismantling, reassembly, test and repair instructions which are detailed in this document.  
These operations are those in use at the latest revision date of the document.

6. Warnings, Cautions, Notes

- A. **WARNING:** Warnings call attention to use of materials, processes, methods, procedures or limits which must be precisely adhered to in order to prevent injury or death of persons.
- B. **CAUTION:** Cautions call attention to use of materials, processes, methods, procedures or limits which must be precisely adhered to in order to prevent damage of equipment.
- C. **NOTE:** Notes call attention to methods, which make the job easier.

7. Identifying Revised Material

- A. Revisions, additions and deletions can be identified by a vertical black line along the left hand margin of the page opposite only that portion of the printed matter that has changed.
- B. A black line in the left hand margin opposite the page number and date will indicate that the text was unchanged but the material was relocated to a different page.
- C. For detailed parts listing an individual code letter "R" as an alternative to a vertical black line can be used on each line to identify revisions.
- D. Each page of a complete manual change is assigned the new revision date.

8. List of Abbreviations

—	A dash before an item number indicates the item
AR	As Required
ASSY	Assembly
EFF	Effectivity
FIG	Figure
NO.	Number
NP	Not Procurable
RF	Reference (Indicates those parts which have their requirements listed elsewhere in the parts list)
UPA	Units Per Assembly



COMPONENTS MAINTENANCE MANUAL  
LED FLASHLIGHT AND LED FLASHLIGHT BRACKET

ATA	Air Transport Association
ABS	Acrylonitrile butadiene styrene
ANSI	American National Standards Institute
ESD	Electrostatic Discharge
FC	Foot Candles
IEC	International Electrotechnical Commission
LED	Light-emitting diode
MTOSS	Maintenance Task Oriented Support System
PN	Part Number
PC	Polycarbonate

List of Abbreviations  
TABLE 1



COMPONENTS MAINTENANCE MANUAL  
LED FLASHLIGHT AND LED FLASHLIGHT BRACKET

INTENTIONALLY LEFT BLANK



COMPONENTS MAINTENANCE MANUAL  
LED FLASHLIGHT AND LED FLASHLIGHT BRACKET  
**DESCRIPTION AND OPERATION**

**\*\* FOR PNs P3APP005000A P3APP005001A**

TASK 25-60-01-870-801-A01

1. General

- A. This manual gives maintenance instructions for the LED FLASHLIGHT and the LED FLASHLIGHT BRACKET.

**\*\* FOR PNs P3APP005000A**

TASK 25-60-04-870-802-A01

2. Description

LED FLASHLIGHT

The LED FLASHLIGHT is a high-intensity, hand-held light for use in emergency situations. The principal components of the LED FLASHLIGHT are a durable PC body, replaceable batteries, O-rings and a high intensity Cree LED.

The LED FLASHLIGHT includes electronic components. Electrostatic Discharge (ESD) precautions need to be adhered to when performing maintenance tasks on it.

The estimated 7 years of in-service life may vary depending on environmental conditions and usage.

Mentioned shelf life and in-service life are estimated based on the testing and calculations conducted using the batteries provided from the manufacturer. Refer to table 7001 and the IPL.

Check your national regulations as well as procedures in the approved aircraft manuals (AFF, AMM, MSM) for installation, inspection and maintenance intervals and instructions. Stricter instructions in any of these sources supersede the instructions in this CMM.

A. Performance

The LED FLASHLIGHT provides high intensity light using three 1.5V Alkaline 'AA' (LR6) batteries. The LED FLASHLIGHT system can remain in-service (in-service is defined as flashlight is correctly installed in aircraft but the system/flashlight is off) for seven years on a fresh battery.

B. Batteries

The flashlight system uses three 1.5V Alkaline 'AA' (LR6) batteries. Spring battery contacts provide reliable electrical contact to the batteries. Battery in-service life is seven years and a shelf life of seven years in storage at 25°C (77°F) ambient temperature. Flashlight systems kept in storage for more than seven years shall have the battery verified before placing it into service. The LED FLASHLIGHT is shipped in an operational state. The battery is connected and no maintenance action is required to activate the system.



COMPONENTS MAINTENANCE MANUAL  
LED FLASHLIGHT AND LED FLASHLIGHT BRACKET

C. Battery Status Check

The LED Flashlight provides a battery status LED and a battery status button to indicate the current battery charge status. Pressing the status button activates the battery status LED. If the status LED illuminates green when the button is pressed, the battery charge is satisfactory and can remain in-service. If the status LED illuminates red when the button is pressed, this indicates to change the battery at earliest opportunity, not to exceed 3 weeks in-service period (in-service is defined as flashlight is correctly installed in aircraft but the system/flashlight is off).

WARNING: FAILURE TO REPLACE THE UNIT MAY RESULT IN NO USABLE LIGHT.

NOTE: Temperature has an impact on the internal resistance of the batteries and temperature changes may cause the status LED to illuminate red when pressed depending on the battery state and temperature. This type of condition is normal with temperature changes and is not viewed as a failure.

D. Materials and Construction

The flashlight body and end caps are made of flame-retardant PC, and the lens is polycarbonate. All openings are sealed with O-rings.

E. Lanyard

The LED FLASHLIGHT assembly includes a lanyard that hooks to the flashlight body when stowed or not in use. The lanyard is used to secure the flashlight to the user when it is necessary to have both hands free.

F. Technical data

LED FLASHLIGHT	
Material	Flame retardant PC confirm to CS25.853
Battery	Three replaceable 1.5V Alkaline 'AA' (LR6) batteries.
Operating Temperature Range*	-40 °C to 70 °C
Light Source	White cree LED
Battery Operational Life** (In-service Life)	7 years installed in the flashlight
Battery Shelf Life**	7 years at 25 °C ± 2 °C
Max Beam Intensity (with fresh battery)	> 2000 candela



COMPONENTS MAINTENANCE MANUAL  
LED FLASHLIGHT AND LED FLASHLIGHT BRACKET

Run time (to the end of battery operational life)	Approximately 4.5 hr
Maximum Weight	190g ±20g
Maximum Dimensions	170 mm x 45 mm

Technical Data  
Table 2

\* In accordance with RTCA DO-160 for operating temperatures. For the batteries refer to manufacturer data sheet

\*\* Battery operational life (in-service Life) is defined as flashlight is correctly installed in aircraft but the system/flashlight is off and pressing the 'battery indicator' button once per day over a period of 7 years under ambient conditions.

Battery shelf life is defined as flashlight in storage under ambient temperature and packed with system off and no battery status checking by pressing the battery indicator button.

Mentioned shelf life and in-service life is based on the testing and calculations conducted using the batteries provided from the manufacturer. Refer to table 7001 and the IPL.

**\*\* FOR PNs P3APP005001A**  
TASK 25-60-04-870-802-B01

2. Description

LED FLASHLIGHT BRACKET

The mounting bracket has multi-interface holes pattern to mount it to flat surfaces such as walls, panels, or bulkheads. The mounting holes are 5,6mm (0.22 in.) dia. Recommended to be installed using NAS1801-3 screws and NAS1149C0332 washers.

A. Materials and Construction

The LED Flashlight Bracket is made up of flame-retardant polycarbonate.

B. Technical data

LED FLASHLIGHT BRACKET	
Material	Flame retardant PC confirm to CS25.853
Operating Temperature Range*	-40 °C to 70 °C



COMPONENTS MAINTENANCE MANUAL  
LED FLASHLIGHT AND LED FLASHLIGHT BRACKET

Maximum Dimensions	178,4 x51,4 x47,8 mm
Maximum Weight	62g

\* In accordance with RTCA DO-160 for operating temperatures.

Technical Data  
Table 3

**\*\* FOR PNs P3APP005000A**  
TASK 25-60-04-870-803-A01

3. Operation

The flashlight is activated by pressing the on/off button. To activate the flashlight press the on/off button once, press again to switch it off.

A two-function Status LED will indicate battery status, illuminating green if the battery charge is satisfactory, and red if the battery charge is low. If there is no indication on the Status LED, refer to Section 1001, Testing and Fault Isolation. This built in test only tests the battery voltage.

**WARNING: FAILURE TO REPLACE THE UNIT MAY RESULT IN NO USABLE LIGHT.**

A. Flashlight Removal

Grasp the flashlight body and pull the flashlight from the mounting bracket. Refer to 12001

B. Flashlight Installation

To install the LED Flashlight into the the LED Flashlight Bracket insert the lens side into the recessed area first then press the rear side down into the bracket allowing for the clamps to fixate the bracket as pictured on the label.

C. Handling

Handle the flashlight carefully. Although the flashlight is of rugged construction and is intended for use in all types of emergencies, it does contain electronic circuits on a printed wiring board. Avoid dropping the flashlight and do not subject it to unnecessary abuse.





COMPONENTS MAINTENANCE MANUAL  
LED FLASHLIGHT AND LED FLASHLIGHT BRACKET

**TESTING AND FAULT ISOLATION**

**\*\* FOR PNs P3APP005000A**

TASK 25-60-04-700-801-A01

1. General

This section contains specific tests and procedures required to determine the condition of the LED FLASHLIGHT system, and return it to service.

A two-function status LED will provide battery condition, illuminating green if the battery charge is satisfactory, and red if the battery charge is low. If there is no indication on the status LED, refer to Section 1001, Testing and Fault Isolation. This built in test only tests the battery voltage.

**\*\* FOR PNs P3APP005000A**

TASK 25-60-04-700-802-A01

2. Testing

A. With the flashlight sufficiently supported (in hand or installed on a retaining device), refer to Section 7001 Assembly, press the battery status button momentarily and release.

B. Examine the Status LED as follows:

- (1) If the LED is illuminated green, the battery is above minimum voltage and can remain in service.
- (2) If the LED is illuminated red, remove the end cap and press the Battery Status Button momentarily and wait approximately 1 min, re-install the end Cap (Refer to ASSEMBLY), switch the flashlight on by pressing the on/off button and keep it switched on for approximately 15 seconds, and while switched on press the battery status button momentarily and release and examine the Status LED as follows:
  - (a) If the LED is illuminated green, the battery is above minimum voltage and can remain in service. Switch off the flashlight and re-install.
  - (b) If the LED is illuminated red, the battery is below minimum voltage and must be replaced at earliest opportunity, not to exceed 3 weeks in-service period (in-service is defined as flashlight is correctly installed in aircraft but the system/flashlight is off).

**WARNING: FAILURE TO REPLACE THE BATTERIES MAY RESULT IN NO USABLE LIGHT.**

**NOTE:** Temperature has an impact on the internal resistance of the battery and temperature changes may cause the status LED to illuminate red when pressed depending on the battery state and temperature. This type of condition is normal with temperature changes and is not viewed as a failure.

(3) If the status LED does not illuminate, refer to the Fault Isolation table 1001.

C. Press on/off button, to switch the LED FLASHLIGHT on and again to switch the LED FLASHLIGHT off.



COMPONENTS MAINTENANCE MANUAL  
LED FLASHLIGHT AND LED FLASHLIGHT BRACKET

D.

**\*\* FOR PNs P3APP005000A**  
TASK 25-60-04-700-803-A01

3. Fault Isolation

If the LED FLASHLIGHT fails the tests or a fault is observed during inspection or use, refer to the Fault Isolation Table 1001 to discover the cause and corrective action.

SYMPTOMS	PROBABLE CAUSE	CORRECTIVE ACTION
Flashlight does not switch ON when pressing the on/off button	Batteries are depleted or have failed.	Remove and replace batteries. Refer to 'ASSEMBLY' for Flashlight Assembly (Battery Installation) procedures. After correct installation of batteries perform inspection check. Refer to 'INSPECTION/CHECK' for check procedures.
	Battery installed incorrectly.	Remove and install batteries correctly. Refer to 'ASSEMBLY' for Flashlight Assembly (Battery Installation) procedures. After correct installation of batteries perform inspection check. Refer to 'INSPECTION/CHECK' for check procedures.
	Electrical failure in flashlight electronics.	If changing the batteries does not solve the fault, there might be an electrical failure in the flashlight electronics. Refer to 'REPAIR' for repair procedures.
Flashlight does not switch OFF when pressing the on/off button.	Electrical failure in flashlight electronics.	Remove and replace batteries. Refer to 'ASSEMBLY' for Flashlight Assembly (Battery Installation) procedures. If changing the batteries does not solve the fault, there might be an electrical failure in the flashlight electronics. Refer to 'REPAIR' for repair procedures.



COMPONENTS MAINTENANCE MANUAL  
LED FLASHLIGHT AND LED FLASHLIGHT BRACKET

Status LED is not showing any light (red or green) when the battery status indicator button is pressed.	Batteries are depleted or have failed.	Remove and replace batteries. Refer to 'ASSEMBLY' for Flashlight Assembly (Battery Installation) procedures. After correct installation of batteries perform inspection check. Refer to 'INSPECTION/CHECK' for check procedures.
	Electrical failure in flashlight electronics.	If changing the batteries does not turn the status Led on, there might be an electrical failure in the flashlight electronics. Refer to 'REPAIR' for repair procedures.
Status LED still shows red light after replacing batteries.	Batteries are depleted or have failed.	Remove and replace batteries with charged/new batteries. Refer to 'ASSEMBLY' for Flashlight Assembly (Battery Installation) procedures. After correct installation of batteries perform inspection check. Refer to 'INSPECTION/CHECK' for check procedures.
	Electrical load not fully discharged within flashlight	Remove batteries, press the Battery Status Button momentarily and wait approximately 1 min for the flashlight electronics to discharge. Reinsert fresh batteries (see above). Refer to 'ASSEMBLY' for Flashlight Assembly (Battery Installation) procedures. After correct installation of batteries perform inspection check. Refer to 'INSPECTION/CHECK' for check procedures. (If necessary, repeat steps several times.)
Flashlight switches on after replacing batteries.	Electrical load not fully discharged within flashlight	Press on/off button to switch flashlight OFF.
	Electrical failure in flashlight electronics	There is an electrical failure in the flashlight. Refer to REPAIR for repair procedures.

Flashlight System Fault Isolation  
Table 1001



COMPONENTS MAINTENANCE MANUAL  
LED FLASHLIGHT AND LED FLASHLIGHT BRACKET

INTENTIONALLY LEFT BLANK



COMPONENTS MAINTENANCE MANUAL  
LED FLASHLIGHT AND LED FLASHLIGHT BRACKET

**DISASSEMBLY**

**\*\* FOR PNs P3APP005000A**

TASK 25-60-04-000-001-A01

1. General Information

- A. Disassemble the LED FLASHLIGHT according to the procedures provided below. Limit disassembly to removing only the components necessary to accomplish the task being performed.
- B. The working area should be clean be free of all foreign objects, debris, unneeded material or tools.

**\*\* FOR PNs P3APP005000A**

TASK 25-60-04-000-002-A01

2. Disassembly Procedures

A. LED Flashlight

NOTE: Refer to IPL figure 01.

- (1) If the flashlight is retained by a tamper shield, do not use sharp or hard objects to remove the shield, as this may damage the flashlight housing.
- (2) Grasp the LED FLASHLIGHT centrally and pull outward to remove it from the mounting bracket.

B. Flashlight Assembly (Battery Removal)

NOTE: Refer to IPL figure 01.

- (1) Remove the FL END CAP CASING 01-050.
- (2) Remove the O-ring and discard.
- (3) Remove the alkaline batteries 01-060 from the FL CENTER CASING 01-010.

NOTE: The lens cap (head assembly) is screwed to the tube and should not be removed.



COMPONENTS MAINTENANCE MANUAL  
LED FLASHLIGHT AND LED FLASHLIGHT BRACKET

INTENTIONALLY LEFT BLANK



COMPONENTS MAINTENANCE MANUAL  
LED FLASHLIGHT AND LED FLASHLIGHT BRACKET

**CLEANING**

**\*\* FOR PNs P3APP005000A P3APP005001A**

TASK 25-60-04-100-801-A01

Cleaning

1. General

Under normal circumstances, the external surfaces of the flashlight and the exposed surface of the mounting bracket will require cleaning. Clean the flashlight system components as described below. Table 4001 below describes the consumables used for general cleaning.

Item	Description	Specification
Cloth	Clean, lint-free	N/A
Detergent	Mild, if required	N/A

Cleaning Consumables  
Table 4001

**CAUTION: DO NOT USE SOLVENTS, CLEANING COMPOUNDS WITH ABRASIVES, OR CHEMICAL CLEANING COMPOUNDS ON ANY FLASHLIGHT COMPONENTS, MOUNTING BRACKET COMPONENTS OR BATTERY.**

**NOTE: USAGE OF CLEANING AGENTS IS RESTRICTED TO ISOPROPYL ALCOHOL AND MILD LIQUID DETERGENT.**

**NOTE: DIRECT CONTACT WITH DISINFECTANT AND INSECTICIDE SHOULD BE AVOIDED. IN CASE OF CONTACT WIPE THE EXPOSED SURFACES WITH A CLEAN LINT-FREE CLOTH.**

- A. Clean the flashlight components except for the batteries using a clean, lint-free cloth moistened with a mild detergent solution if necessary. Wipe off any residues of the cleaning agents from the components thoroughly with a clean, lint-free cloth or allow to air dry.
- B. Clean the mounting bracket using a clean, lint-free cloth moistened with a mild detergent solution if necessary. Wipe off any residues of the cleaning agents from the components thoroughly with a clean, lint-free cloth or allow to air dry.



COMPONENTS MAINTENANCE MANUAL  
LED FLASHLIGHT AND LED FLASHLIGHT BRACKET

INTENTIONALLY LEFT BLANK





COMPONENTS MAINTENANCE MANUAL  
LED FLASHLIGHT AND LED FLASHLIGHT BRACKET

**INSPECTION/CHECK**

**\*\* FOR PNs P3APP005000A P3APP005001A**  
TASK 25-60-04-200-001-A01

1. General

This section provides the check instructions for the LED FLASHLIGHT and the LED FLASHLIGHT BRACKET.

Check your national regulations as well as procedures in the approved aircraft manuals (AFF, AMM, MSM) for installation, inspection and maintenance intervals and instructions. Stricter instructions in any of these sources supersede the instructions in this CMM.

**\*\* FOR PNs P3APP005000A**  
TASK 25-60-04-200-002-A01

2. Check

Perform check of the LED FLASHLIGHT, according to Table 5001 below.

Inspection/Action	Requirements	Task	Recommended Interval
Visually check the flashlight	No visible cracks, damage or deformation	Remove and replace damaged or deteriorating components Refer to REPAIR	Daily Inspection
	Lanyard in attached	Re-attach the Lanyard Refer to REPAIR	Daily Inspection
Press the "Status Battery" button and examine the LED.	If the LED illuminates GREEN,	No task	Daily Inspection
	If the LED illuminates RED,	refer to Section 1001, Testing and Fault Isolation Replace batteries at earliest opportunity Refer to REPAIR	
Press the ON/OFF BUTTON to switch on the flashlight and then switch off.	The flashlight should turn on after pressing and turn off after pressing again.	Refer to Testing and Fault Isolation	Monthly Inspection
Clean the flashlight system.	No visible stains and/or contamination	Clean away any contamination, refer to CLEANING.	Upon detection

Check of the LED Flashlight System  
Table 5001



COMPONENTS MAINTENANCE MANUAL  
LED FLASHLIGHT AND LED FLASHLIGHT BRACKET

A. Updating of the Expiration Date  
NOTE: Refer to figure 5001

NOTE: The following RFID Reader/Writer screens and instructions are taken from an arbitrary RFID Reader/Writer and are included as an example of one method and interface to add maintenance history and scratch pad data. Actual RFID Reader/Writer screen for this operation may differ from the instruction shown.

- (1) Read a tag and select the "LIFECYCLE" tab button of the screen.
- (2) Click on the "EDIT" button to modify the "Expiration Date".
- (3) Select the new expiration date and click on "Done".
- (4) Click on the "NEXT" button
- (5) Make sure that the "Life Cycle Record update" is shown on the screen.

COMPONENTS MAINTENANCE MANUAL  
LED FLASHLIGHT AND LED FLASHLIGHT BRACKET

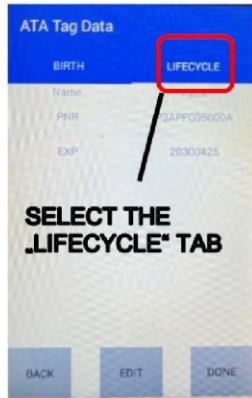

Figure 1: STEP-1



Figure 2: STEP-2

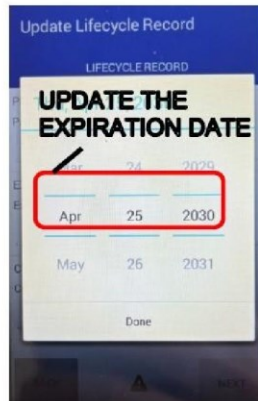

Figure 3: STEP-3

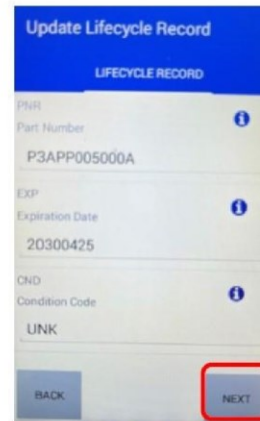

Figure 4: STEP-4

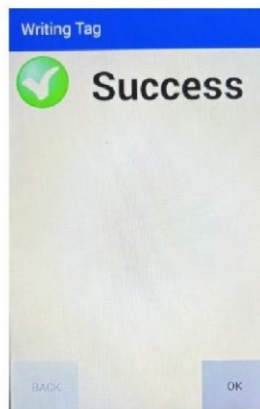

Figure 5: STEP-5

2560045001

Update of the Flashlight Expiration Date  
Figure 5001



COMPONENTS MAINTENANCE MANUAL  
LED FLASHLIGHT AND LED FLASHLIGHT BRACKET

**\*\* FOR PNs P3APP005001A**  
TASK 25-60-04-200-003-A01

3. Check

Perform check of the LED FLASHLIGHT BRACKET according to Table 5002 below.

Inspection/Action	Requirements	Task	Recommended Interval
Visually Check the LED flashlight bracket.	No visible cracks, damage or deformation	Remove and replace damaged or deteriorating components Refer to REPAIR	Daily Inspection
Clean the LED flashlight bracket.	No visible stains and/or contamination	Clean away any contamination, refer to CLEANING.	Upon detection

Check of the LED FLASHLIGHT BRACKET

Table 5002



COMPONENTS MAINTENANCE MANUAL  
LED FLASHLIGHT AND LED FLASHLIGHT BRACKET

INTENTIONALLY LEFT BLANK



COMPONENTS MAINTENANCE MANUAL  
LED FLASHLIGHT AND LED FLASHLIGHT BRACKET

**REPAIR**

**\*\* FOR PNs P3APP005000A P3APP005001A**  
TASK 25-60-04-300-001-A01

1. General

This section provides instructions for replacing components that are damaged or have failed in the flashlight system. The repair procedures are limited to removal and replacement of components.

**\*\* FOR PNs P3APP005000A**  
TASK 25-60-04-300-002-A01

2. Repair Procedures

A. Battery Replacement

**CAUTION: BATTERIES THAT SHOW NO SIGNS OF DAMAGE OR CHEMICAL EXPOSURE CAN BE HANDLED WITHOUT THE NEED OF PPE ITEMS.**

Batteries that are damaged and/or have signs of chemical exposure should be handled with the appropriate PPE items. Direct exposure to any part of the body should be avoided. The exposed battery parts should be carefully placed in a container that is capable of holding and sealing the chemicals to avoid additional exposure.

If in case of direct contact of the battery chemicals with a surrounding area, immediately flush the area with water or other acceptable cleansing fluid. Seek immediate medical attention if necessary.

All spent or used batteries should be stored in a cool dry area until they can be properly disposed.

If the batteries requires replacement, remove and replace the batteries as per instructions located in Section 3001, Disassembly and 7001, Assembly.

B. Lanyard Repair

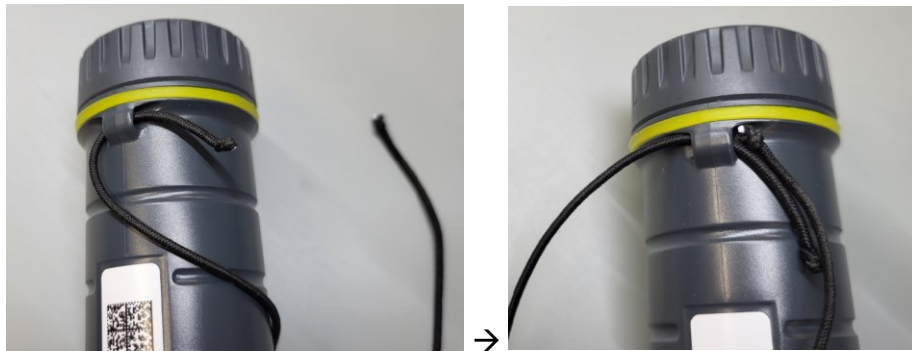

*Figure 1: Lanyard knot outside*

COMPONENTS MAINTENANCE MANUAL  
LED FLASHLIGHT AND LED FLASHLIGHT BRACKET

The wrist lanyard can be re-attached following the below steps:

- Push the knot that is still in place a bit outside.
- Place the free knot on the other side of the hook
- Push the knot gently using a small head screwdriver or similar tool. Care should be made to not damage the flashlight
- Pull back the lanyard so that both knots are back in place



### C. LED FLASHLIGHT Replacement

The only replaceable component on the LED Flashlight are the batteries and the o-rings. If any other component in the LED Flashlight fails, replace the entire LED Flashlight assembly.

The O-ring is a replaceable item and is replaced each time the batteries are replaced.

**\*\* FOR PNs P3APP005001A**

TASK 25-60-04-300-003-A01

#### 3. Repair Procedures

##### A. LED FLASHLIGHT BRACKET replacement

There are no repairable/replaceable items on the LED FLASHLIGHT BRACKET. If any component on the bracket fails, replace the LED FLASHLIGHT BRACKET.



COMPONENTS MAINTENANCE MANUAL  
LED FLASHLIGHT AND LED FLASHLIGHT BRACKET

INTENTIONALLY LEFT BLANK





COMPONENTS MAINTENANCE MANUAL  
LED FLASHLIGHT AND LED FLASHLIGHT BRACKET

**ASSEMBLY**

**\*\* FOR PNs P3APP005000A**  
TASK 25-60-04-400-001-A01

1. General

Assemble the flashlight assembly and install it into the mounting bracket according to the instructions provided below.

**\*\* FOR PNs P3APP005000A**  
TASK 25-60-04-400-002-A01

2. Assembly of the Flashlight (Battery Installation)

Table 7001 below describes the consumables used for assembly of the flashlight.

Reference	Description
P3PRT000274A *	Industrial 1.5V Alkaline 'AA' (LR6) batteries
P3PRT000844E **	O-ring (32,00x2,00-EPDM70)

Flashlight Assembly Consumables  
Table 7001

\* Recommended to be used. The operator may use any commercially available industrial AA alkaline batteries (LR6).

\*\* Recommended to be used. The operator may use any commercially available O-ring that fulfills the mentioned description.

A. Flashlight Assembly (Battery Installation)  
NOTE: Refer to figure 01 and figure 7001.

(1) Install the alkaline batteries 01-060 into the FL CENTRE CASING 01-010.

NOTE: Make sure that the batteries 01-060 is correctly positioned inside the FL center casing 01-050. Refer to figure 1 and figure 7001.

NOTE: Each time the battery is replaced, the O-ring must be replaced.

(2) Install a new O-ring.

(3) Install the FL END CAP CASING 01-050.

(4) Make sure that the status LED illuminates GREEN when the "Battery Status Button" is pressed.

COMPONENTS MAINTENANCE MANUAL  
LED FLASHLIGHT AND LED FLASHLIGHT BRACKET

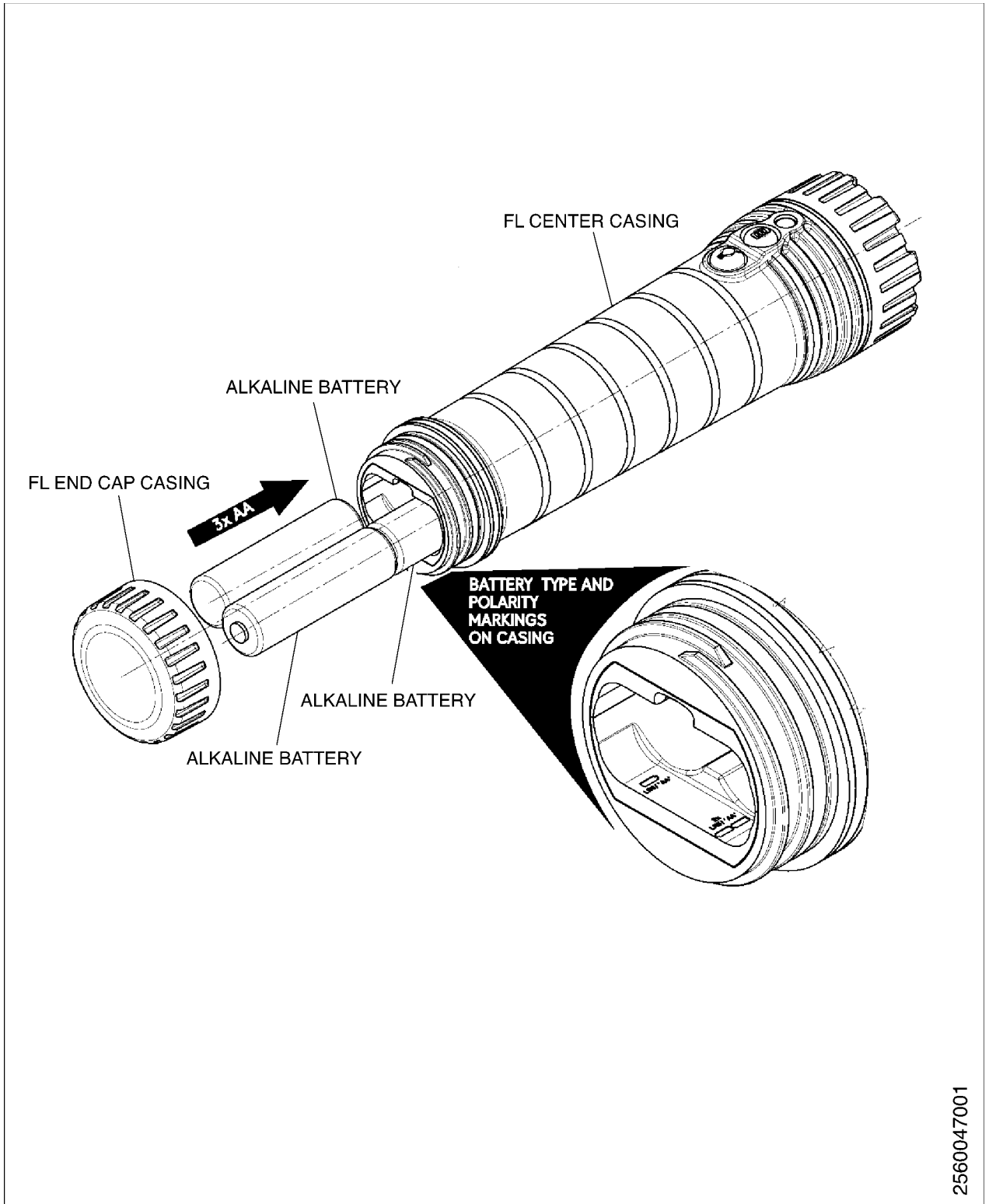

2560047001

Assembly of the Flashlight (Battery Installation)  
Figure 7001



COMPONENTS MAINTENANCE MANUAL  
LED FLASHLIGHT AND LED FLASHLIGHT BRACKET  
**FITS AND CLEARANCES**

**\*\* FOR PNs P3APP005000A**

NOT APPLICABLE



COMPONENTS MAINTENANCE MANUAL  
LED FLASHLIGHT AND LED FLASHLIGHT BRACKET

INTENTIONALLY LEFT BLANK



COMPONENTS MAINTENANCE MANUAL  
LED FLASHLIGHT AND LED FLASHLIGHT BRACKET

**SPECIAL TOOLS, FIXTURES,  
EQUIPMENT AND CONSUMABLES**

**\*\* FOR PNs P3APP005000A**

NOT APPLICABLE

**25-60-04**

Rev. No.  
Rev. Date  
Page

00  
Nov 13/2023  
9001



COMPONENTS MAINTENANCE MANUAL  
LED FLASHLIGHT AND LED FLASHLIGHT BRACKET

INTENTIONALLY LEFT BLANK



COMPONENTS MAINTENANCE MANUAL  
LED FLASHLIGHT AND LED FLASHLIGHT BRACKET  
SPECIAL PROCEDURES

**\*\* FOR PNs P3APP005000A**

NOT APPLICABLE

**25-60-04**

Rev. No.  
Rev. Date  
Page

00  
Nov 13/2023  
11001



COMPONENTS MAINTENANCE MANUAL  
LED FLASHLIGHT AND LED FLASHLIGHT BRACKET

INTENTIONALLY LEFT BLANK





COMPONENTS MAINTENANCE MANUAL  
LED FLASHLIGHT AND LED FLASHLIGHT BRACKET

**REMOVAL**

**\*\* FOR PNs P3APP005001A**

TASK 25-60-04-400-001-A01

1. General

Self-explanatory.

**\*\* FOR PNs P3APP005001A**

TASK 25-60-04-400-002-A01

2. Removal of the LED FLASHLIGHT and the LED FLASHLIGHT BRACKET

A. Remove the LED FLASHLIGHT from the bracket as follows:

- (1) Pull out the LED FLASHLIGHT from the handle so it is released from the clamps.
- (2) Move the flashlight outwards tilted to release it.

B. Remove the LED FLASHLIGHT BRACKET:

- (1) Remove the screws and the bracket from the structure



COMPONENTS MAINTENANCE MANUAL  
LED FLASHLIGHT AND LED FLASHLIGHT BRACKET

INTENTIONALLY LEFT BLANK



COMPONENTS MAINTENANCE MANUAL  
LED FLASHLIGHT AND LED FLASHLIGHT BRACKET

**INSTALLATION**

**\*\* FOR PNs P3APP005001A**

TASK 25-60-04-400-001-A01

1. General

Self-explanatory.

**\*\* FOR PNs P3APP005001A**

TASK 25-60-04-400-002-A01

2. Installation of the LED FLASHLIGHT BRACKET

A. Install the LED FLASHLIGHT BRACKET as follows:

- (1) Position the LED FLASHLIGHT BRACKET on the structure.
- (2) Install the screws with the washers, hand tight

B. Install the LED FLASHLIGHT on the bracket as follows:

- (1) Move the LED FLASHLIGHT inwards tilted to position the front edge in the recess with the lanyard facing the bracket.
- (2) Push the LED FLASHLIGHT towards the bracket so that is secured in the clamps.



COMPONENTS MAINTENANCE MANUAL  
LED FLASHLIGHT AND LED FLASHLIGHT BRACKET

INTENTIONALLY LEFT BLANK



COMPONENTS MAINTENANCE MANUAL  
LED FLASHLIGHT AND LED FLASHLIGHT BRACKET

**SERVICING**

**\*\* FOR PNs P3APP005000A**

NOT APPLICABLE



COMPONENTS MAINTENANCE MANUAL  
LED FLASHLIGHT AND LED FLASHLIGHT BRACKET

INTENTIONALLY LEFT BLANK



COMPONENTS MAINTENANCE MANUAL  
LED FLASHLIGHT AND LED FLASHLIGHT BRACKET

**STORAGE INCLUDING**  
**TRANSPORTATION**

**\*\* FOR PNs P3APP005000A**  
TASK 25-60-04-550-001-A01

1. Storage applicable

All spent or used batteries should be stored in a cool dry area until they can be properly disposed.

- A. Store the LED FLASHLIGHT in a dry, well-ventilated, temperature- controlled environment away from direct sunlight.

NOTE : Normal storage temperature range should be  $25^{\circ} \pm 3^{\circ}$  C. Storage of the Flashlight or the battery at different temperatures retards battery degradation

- B. If the aircraft is to be idled in an elevated temperature environment [up to a maximum of  $70^{\circ}$  C ] for more than 7 days, remove the LED FLASHLIGHT and place it in temperature-controlled storage.
- C. If the temperature is above  $70^{\circ}$  C, remove the LED FLASHLIGHT immediately and place it in temperature-controlled storage.



COMPONENTS MAINTENANCE MANUAL  
LED FLASHLIGHT AND LED FLASHLIGHT BRACKET

INTENTIONALLY LEFT BLANK





COMPONENTS MAINTENANCE MANUAL  
LED FLASHLIGHT AND LED FLASHLIGHT BRACKET

**REWORK**

**\*\* FOR PNs P3APP005000A**

NOT APPLICABLE



COMPONENTS MAINTENANCE MANUAL  
LED FLASHLIGHT AND LED FLASHLIGHT BRACKET

INTENTIONALLY LEFT BLANK



COMPONENTS MAINTENANCE MANUAL  
LED FLASHLIGHT AND LED FLASHLIGHT BRACKET

**ILLUSTRATED PARTS LIST**

**25-60-04**

Rev. No.  
Rev. Date  
Page

00  
Nov 13/2023  
IPL-TP-10001



COMPONENTS MAINTENANCE MANUAL  
LED FLASHLIGHT AND LED FLASHLIGHT BRACKET

INTENTIONALLY LEFT BLANK



COMPONENTS MAINTENANCE MANUAL  
LED FLASHLIGHT AND LED FLASHLIGHT BRACKET

IPL INTRODUCTION

1. General Information

- A. This ILLUSTRATED PARTS LIST (IPL) contains the complete listing of all replaceable major assemblies of the LED FLASHLIGHT.

2. Organization

- A. The IPL is divided into the following sections:

(1) Introduction

The introduction contains all explanatory information for the individual sections as is necessary for using the IPL. The introduction further contains a list of manufacturer codes together with manufacturer names and addresses.

(2) Numerical Index

This section contains a listing of part numbers of all items listed in the detailed parts list in alphanumerical sequence with cross-reference to respective Fig./Item Nos. as well as units per assy.

The order of precedence in beginning the part number arrangement at the outmost left-hand (first) position is as follows:

- letters A through Z (except 'O' to be considered as zero)
- numerals 0 to 9.

For subsequent rows, the order is:

- letters A through Z (except 'O' to be considered as zero)
- numerals 0 to 9.

(3) Detailed Parts List

(a) Column "FIG. / ITEM"

The first number in the first line of a page indicates the number of the figure illustrating the part. The second number indicates the item number by which the part is identified on the illustration. A dash placed before the item number indicates that the part is not illustrated.

(b) Column "PART NUMBER"

The part number column contains the original manufacturers' part numbers. When standard part numbers are used, the standard part number is listed in this column.

(c) Column "AIRLINE STOCK NO."

This column is left blank for airline internal use.

(d) Column "NOMENCLATURE"

- Indenture System



COMPONENTS MAINTENANCE MANUAL  
LED FLASHLIGHT AND LED FLASHLIGHT BRACKET

The indenture system used in the Detailed Parts List shows the relationship of parts and assemblies to next higher assemblies as follows:

1234567

Assembly

Attaching Parts for Assembly

\* \* \*

. Detail Parts for Assembly

. . Subassembly

. . Attaching Parts for Subassembly

\* \* \*

. . . Detail Parts for Subassembly

. . . . Sub-Subassembly

. . . . Attaching Parts for Sub-Subassembly

\* \* \*

.....Detail Parts for Sub-Subassembly

– Attaching parts

The attaching parts are shown directly after the assembly or the part thereof. They are listed under the same indenture number as the item they attach, and are preceded by the words 'ATTACHING PARTS' and are followed by three asterisks.

– Vendor Codes

Parts manufactured by companies other than umlaut engineering GmbH are identified by an appropriate vendor code following the nomenclature.

Vendor codes are in accordance with current issues of U.S. Federal Supply Codes for Manufacturer Handbooks H4-1, H4-2 and H4-3 and/or in accordance with applicable European regulations and are preceded by the letter 'V'. Standard parts such as AN, DIN, MS etc. are not identified by a vendor code. When there is no known vendor code, the abbreviated name of the vendor is listed in lieu of the vendor code.

(e) Column “EFF CODE”

Alpha variants A-Z (except I and O) may be assigned to an existing item number in the FIG-ITEM column to show configuration differences, optional parts, etc. Alpha variant items are not shown on the illustration when the appearance and location of the alpha variant are the same as the basic item. In the EFF CODE column, part

COMPONENTS MAINTENANCE MANUAL  
LED FLASHLIGHT AND LED FLASHLIGHT BRACKET

applicability is indicated with respect to the top assemblies. A part shown with an effectivity code is only used in the top assembly variant which has the same effectivity code. The absence of a code indicates that the part is common to all variants of the top assembly.

(f) Column “UNITS PER ASSY”

This column contains the quantity of a specific catalog sequence numbered part required in the build sequence of only one (where more than one exists), next higher sub-sub-assembly, sub-assembly, assembly, or installation level as applicable. For bulk items, the letters 'AR' are inserted in the quantity column to indicate 'As Required'. Whenever items are listed for reference purposes, 'RF' is inserted.

3. How to use the IPL

A. If the part number is known

- (1) Find the part number in the numerical index and note figure and item number.
- (2) Turn to figure.
- (3) Locate the part on the illustration and in the parts list by item number.

B. If the part number is unknown

- (1) Please refer to Figure 1 and look for the figure item number of the part.
- (2) Note the figure item number.
- (3) Turn to the figure item list and find the corresponding part number.

C. Umlaut engineering GmbH Part Numbering System

- (1) Each part, assembly and installation is assigned a "Part" number consisting of the basic engineering drawing number. Supplementary numbers appended to the engineering drawing number identify parts, assemblies or installations which are detailed.



COMPONENTS MAINTENANCE MANUAL  
LED FLASHLIGHT AND LED FLASHLIGHT BRACKET

INTENTIONALLY LEFT BLANK





COMPONENTS MAINTENANCE MANUAL  
LED FLASHLIGHT AND LED FLASHLIGHT BRACKET  
NUMERICAL INDEX

PART NUMBER	AIRLINE STOCK NUMBER	FIG.	ITEM	TTL REQ
P3APP005000A		1	001A	RF
P3PRT000274A		1	10	3
P3PRT000844E		1	20	1



COMPONENTS MAINTENANCE MANUAL  
LED FLASHLIGHT AND LED FLASHLIGHT BRACKET

INTENTIONALLY LEFT BLANK



COMPONENTS MAINTENANCE MANUAL  
LED FLASHLIGHT AND LED FLASHLIGHT BRACKET

**DETAILED PARTS LIST**

**25-60-04**

Rev. No.  
Rev. Date  
Page

00  
Nov 13/2023  
DPL 10001

COMPONENTS MAINTENANCE MANUAL  
LED FLASHLIGHT AND LED FLASHLIGHT BRACKET

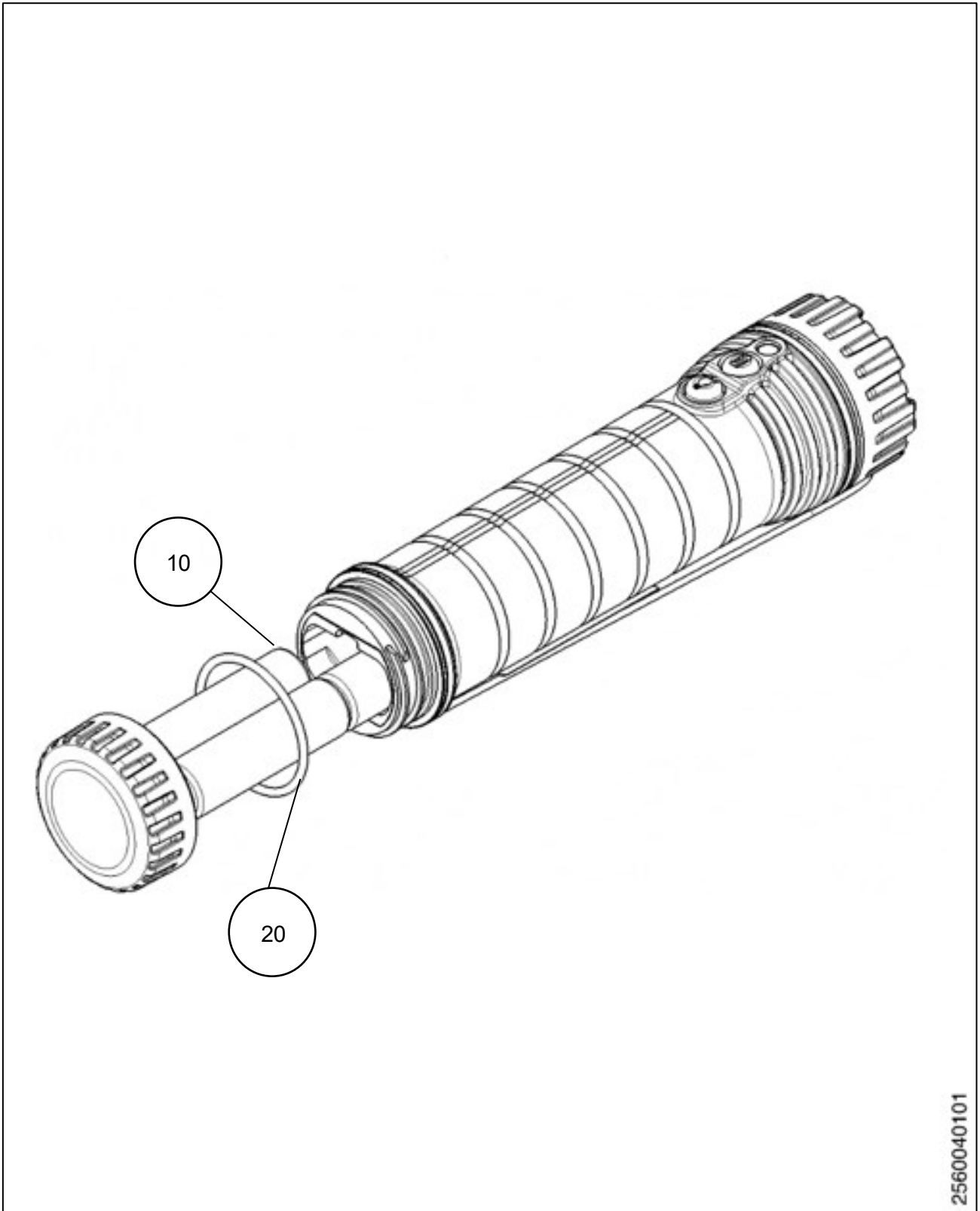

2560040101

LED FLASHLIGHT  
FIGURE 1



COMPONENTS MAINTENANCE MANUAL  
LED FLASHLIGHT AND LED FLASHLIGHT BRACKET

FIG. ITEM	PART NUMBER	AIRL. STOC-K NO.	NOMENCLATURE 1234567	EFF CODE	UPA
1					
- 001A	P3APP005000A		LED FLASHLIGHT		RF
10	P3PRT000274A		ALKALINE BATTERY		3
20	P3PRT000844E		O-RING		1

- ITEM NOT ILLUSTRATED

COMPONENTS MAINTENANCE MANUAL  
LED FLASHLIGHT AND LED FLASHLIGHT BRACKET

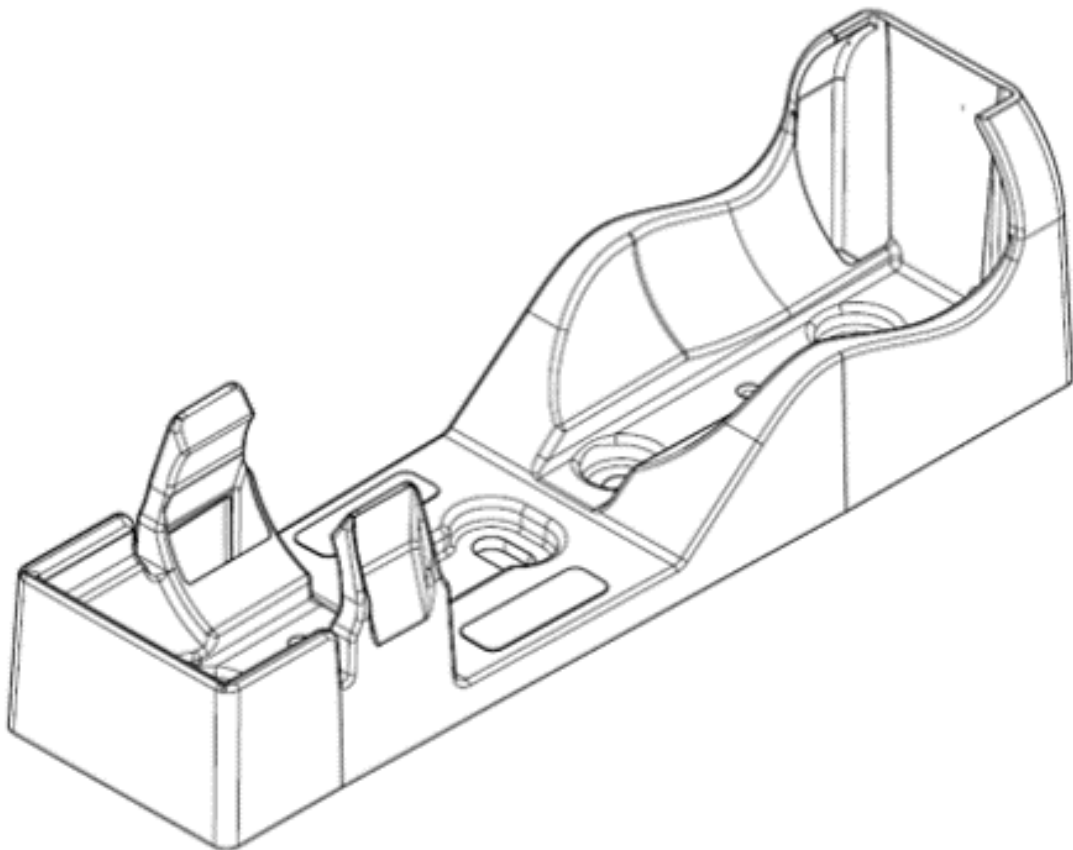

2560040201

LED FLASHLIGHT BRACKET  
FIGURE 2



COMPONENTS MAINTENANCE MANUAL  
LED FLASHLIGHT AND LED FLASHLIGHT BRACKET

FIG. ITEM	PART NUMBER	AIRL. STOC- K NO.	NOMENCLATURE 1234567	EFF CODE	UPA
2 - 002A	P3APP005001A		LED FLASHLIGHT BRACKET		RF

- ITEM NOT ILLSUTRATED